

2024 – European Spallation Source (ESS), Sweden six MotoSuiveurs MS3S for casks 1, 2, 4, 5, 7 & 9

Year : 2023

Site : ESS ERIC, Lund, Sweden (world's most powerful
neutron source)

Manufacturers : TBD

Active Cells Facility at ESS

SWL : 16.2 to 65 ton

MS3SR, Remote Recovery Mechanisms

Stopping Distance 10 mm

Torque Limiter TL100, 58Nm



2023 – European Spallation Source (ESS), Sweden MotoSuiveur MS3SR for Cask 3

Year : 2023

Site : ESS ERIC, Lund, Sweden
(world's most powerful neutron
source)

Manufacturer : Asturfeito, Spain

Active Cells Facility at ESS

SWL : 35 ton

MS3SR, Remote Recovery
Mechanisms

Stopping Distance 10 mm

Torque Limiter TL100, 58Nm



asturfeito



EUROPEAN
SPALLATION
SOURCE

2023 – CEA Saclay, INB72 - MotoSuiveur MS3S

Year : 2023

Site : CEA Saclay, INB72, B114 - France

Manufacturer : EIFFAGE Métal, France

SWL : 18 ton

MS3S

Stopping Distance 30 mm

Torque Limiter TL100, 95Nm



2022 – Ignalina NPP, Lithuania 5t Street hoist Motosuiveur upgrade

Year : 2022

Site : Ignalina NPP (Lithuania)

Nuclear waste

SWL: 5 ton

Upgrade with MotoSuiveur, Remote Load Recovery

Size: MS1HR; 7850 Nm

Stopping Distance : <30 mm

Torque Limiter LC63, 30 Nm

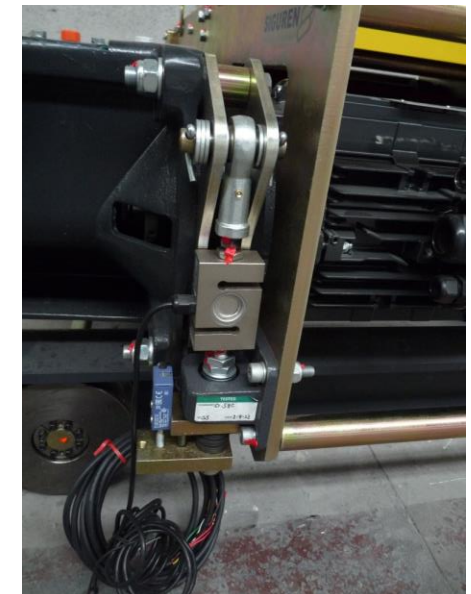

2019 – MAGNOX Berkeley, UK four MotoSuiveurs MS3SR

Year : 2019

Site : Magnox Berkeley (UK)

Manufacturer : SCX Special Projects

Intermediate Level Waste Box-
Handling Cranes

SWL : 2x 32 ton

Two times two MS2SR, Synchronized
Remote Recovery Mechanisms

Stopping Distance 30 mm

Four Torque Limiters TL80, 55Nm

SCX
Special Projects

 **Magnox**



2017 - 2019 – Sellafield, UK six MotoSuiveurs MS1H

Years : 2017-2019

Site : Sellafield, UK (various buildings)

Nuclear Waste Handling

SWL: 10 ton

Six MotoSuiveurs

Size: MS1H

Stopping Distance : <30 mm

Six Torque Limiters TL63



Sellafield Ltd

SCX
Special Projects

2018 – Rolls-Royce Derby and Raynesway, UK two MotoSuiveurs MS7HR

Year : 2018

Site : Rolls-Royce (Submarines) Derby et
Raynesway, UK

Manufacturer : SCX Special Projects

Nuclear Product Facility Crane

SWL : 125 ton

Two MotoSuiveurs with Remote Load
Recovery

Size MS7 ; Stopping Distance : <25 mm

Torque Limiter TL125, 400 Nm



Rolls-Royce

SCX
Special Projects

2018 – BAE Systems Barrow-in-Furness, UK MotoSuiveurs MS4HR and MS2HR

Year : 2018

Site : BAE Systems D59 Barrow-in-Furness (UK)

Manufacturer : SCX Special Projects

Two High Safety Cranes

SWL : 25 ton, 5 ton

MS4HR – 41135 Nm

MS2HR – 15540 Nm

Stopping Distance 30 mm

Torque Limiter TL100, 180 Nm



BAE SYSTEMS

SCX 
 *Special Projects*

2018 – BAE Systems Barrow-in-Furness, UK MotoSuiveur MS7HR

Year : 2018

Site : BAE Systems D59 Barrow-in-Furness (UK)

Manufacturer : SCX Special Projects

High Safety Crane

SWL : 150 ton

MS7HR – 255000 Nm

Stopping Distance 50 mm

Torque Limiter TL125, 600 Nm

BAE SYSTEMS

SCX
Special Projects

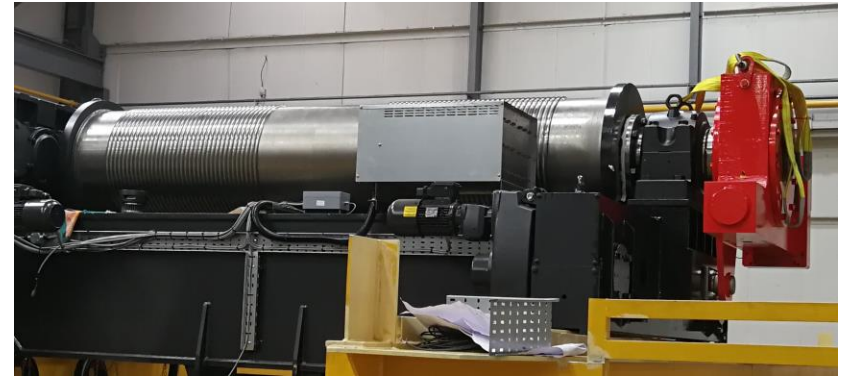

2017 – Rolls-Royce Raynesway, UK two MotoSuiveur MS0HR

Year : 2017

Site : Rolls-Royce Raynesway, UK

Clean Room Cranes

SWL: 1 ton

Two MotoSuiveurs with Remote Load

Recovery working on Safety low
voltage DC

Size: MS0HR; 2600 Nm

Stopping Distance : <15 mm

Torque Limiter LC50, 30 Nm



2017 – Sellafeld B30, UK two MotoSuiveurs MS6HR et MS3HR

Year : 2017

Site : Sellafeld Bâtiment B30 (UK)

Manufacturer : REEL

High Safety Crane

SWL : 55 ton + 15 ton

MS6HR 135000 Nm with Remote Recovery

MS3HR 27750 Nm with Remote Recovery

Stopping Distance 40 mm

Torque Limiters TL100 and TL125



Sellafield Ltd



2017 – CNPE Dounreay, UK MotoSuiveur MS1HR

Year : 2017

Site : CNPE Dounreay (UK)

Manufacturer : SCX Special Projects

Nuclear Waste Casks handling Crane

SWL : 3 ton

MS1HR – 4620 Nm

Stopping Distance 30 mm

Torque Limiter TL63, 45 Nm



2016 – Urenco Capenhurst, UK two MotoSuiveurs MS4H

Year : 2016

Site : Urenco Capenhurst (UK)

Manufacturer : SCX Special Projects

Two Goliath cranes for d'Uranium
Casks

SWL : 28 ton

MS4H, 35000 Nm

Stopping Distance 30 mm

Torque Limiter TL125, 180 Nm



2015 – Dounreay NPP, UK two MotoSuiveurs MS3HR

Year : 2015

Site : CNPE Dounreay (UK)

Manufacturer : SCX Special Projects

Shaft Intervention Platform

SWL : 10 ton

Two redundant MS3HR

Stopping Distance 10 mm



2015 – ONDRAF PAMELA building, Belgium MotoSuiveur MS0FR

Year : 2015

Site : ONDRAF PAMELA (Belgium)

Manufacturer : SIGUREN

In-cell crane nuclear waste Na&NaK

SWL : 550 daN

MS0FR with Remote Load Recovery,
chain hoist

Stopping Distance 20 mm



2012 – Ignalina NPP (Lithuania) MotoSuiveurs MS2H & MS1H on standard hoists

Year: 2012

Site : Ignalina NPP (Lithuania)

Manufacturer : SIGUREN

Two Nuclear Waste Cranes

SWL : 8 ton,4 ton

MS2H – 15892 Nm

MS1H – 5515 Nm

Stopping Distance 30 mm



2012 – CEA Cadarache, France MotoSuiveur MS1FR sur palan du commerce

Year : 2012

Site : CEA Cadarache

Manufacturer: SIGUREN

In-cell crane for waste
characterization

SWL : 10 ton

MS1FR with Remote Load
Recovery

Stopping Distance 20 mm

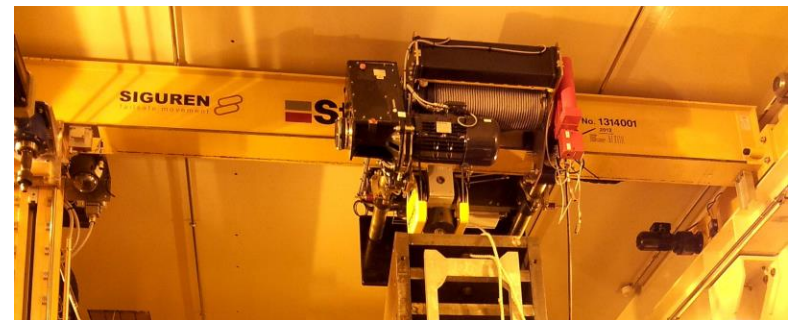
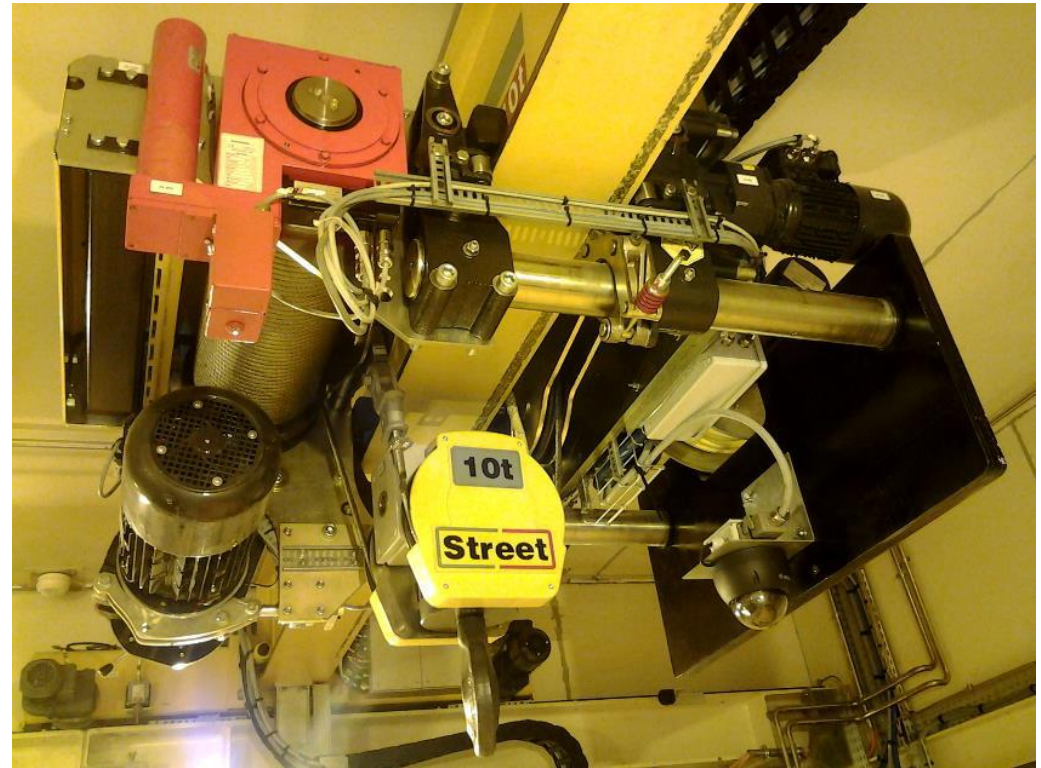

2012 – UK-based Defense Company MotoSuiveur MS1FR

Year : 2012

Site : (UK)

Manufacturer: SCX Special Projects

Hazardous materials crane

SWL : 5 ton, de-rated to 2 ton

MS1H

Stopping Distance 20 mm

Torque Limiter TL63



2012 –Bradwell NPP, UK MotoSuiveur MS1HR

Year : 2012

Site : CNPE Bradwell (UK)

Manufacturer : SCX Special Projects

In-Cell crane for removal, handling
and disposal of fuel element debris

SWL : 5 ton

MS1HR- 9500 Nm

Remote Load Recovery

Stopping Distance 25 mm

SCX
Special Projects

 **Magnox**

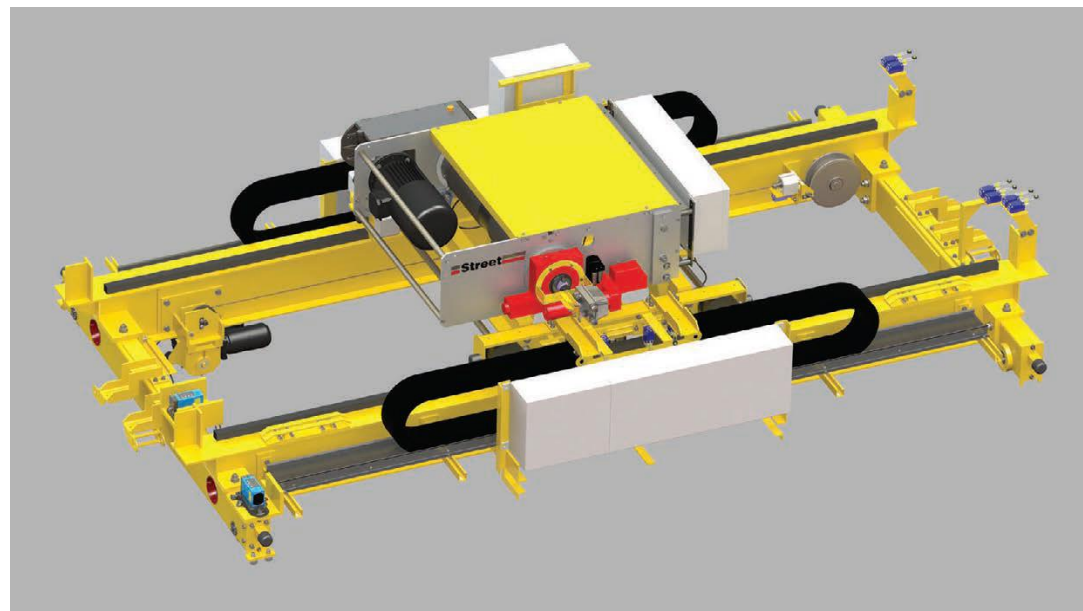

2011 –Sellafield B30, UK two MotoSuiveurs MS2HR

Year : 2011

Manufacturer : SCX Special
Projects

Site : Sellafield B30

**Two in-cell nuclear waste
cranes**

SWL : 5 ton

MS2HR- 12500 Nm

Remote load Recovery

Stopping distance 40 mm

Torque Limiter TL100, 120 Nm



Sellafield Ltd

