

motosuiveur UNIT
MS7LFFC2F1

Model

Rev. 09022022

Configuration

size	7
type	Passive friction (F)
mounting type	Foot mounted bearing (F)
lowering rot. dir.	Clockwise (C)
reaction pos.	(2)
driving	Torque flange (F)
motor pos.	(1)
load recovery	x
recovery pos.	x

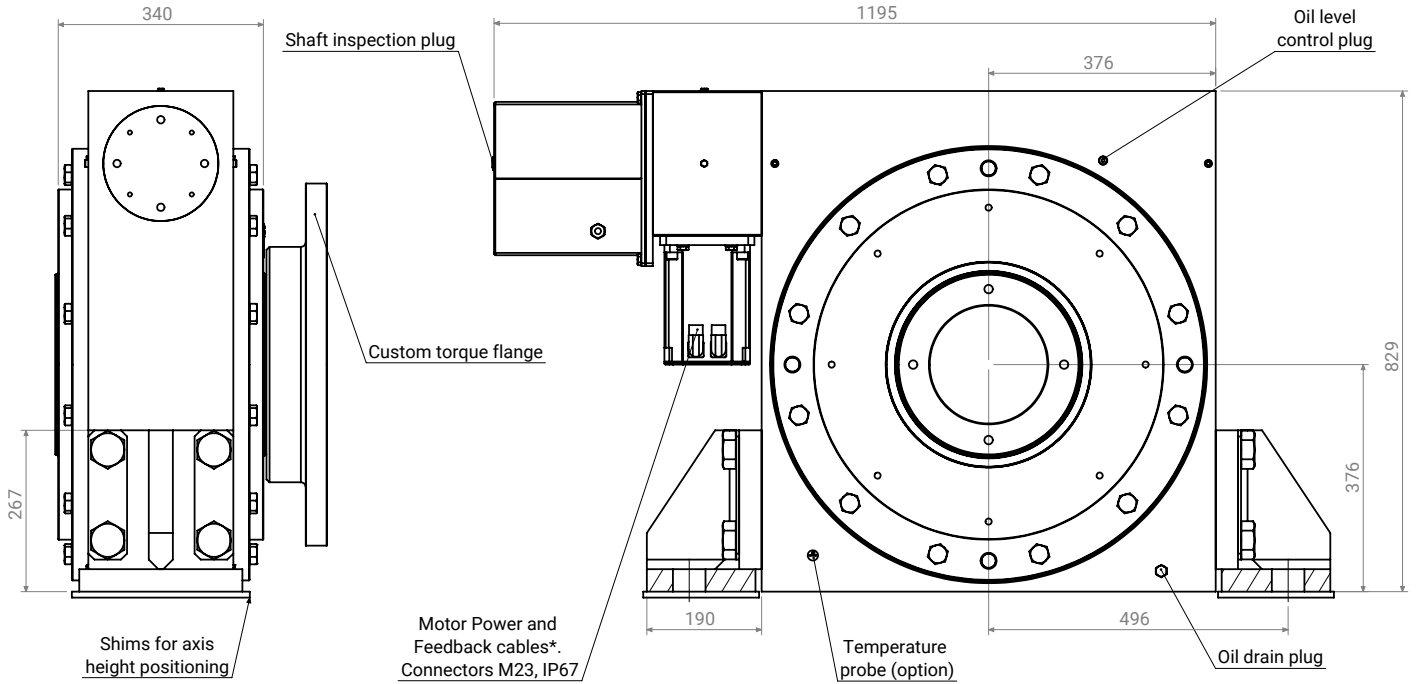

Arrest torque calculation

$$C_{MS} \geq 1.4 \times C_S$$

(C_S : Static torque at the hoist drum)

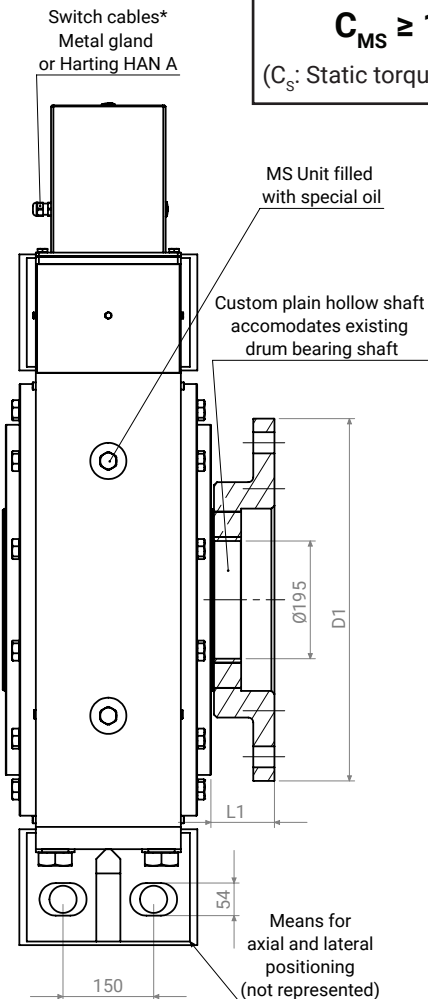

Max. arrest torque** (C_{MS})	Nm	225,000
Max. drum speed	rpm	24
Worm / worm wheel ratio		45
IP rating		IP65
Operational ambient temp. limit		-10°C
Servomotor power supply options		400VAC, three phases 230VAC, single phase 48VDC

Dimensions

L x W x H = 1195 x 340 x 829 mm

Max. weight (this configuration)	kg	1450
Oil volume	L	18.6
Control cabinet dimensions	mm	600 x 600 x 250

Torque flange

D1	mm	Custom
L1	mm	Custom

Drum bearing

Vertical capacity (up&down)	N	520,000
Horiz. lateral capacity	N	260,000
Horiz. axial capacity (locating)	N	104,000
Angular accomodation	°	±3

Mounting studs

Quantity		4
Size		M42

* All cables go to MotoSuiveur control cabinet

** for required C_{MS} lower than 130,200 Nm, consider MS6F Unit models.